



!

## IMPORTANT

MUST BE TESTED

CALL TO TEST GPS TRACKING DEVICE BEFORE CLOSING UP DASH  
FAILURE TO FOLLOW THESE INSTRUCTIONS MAY DAMAGE EQUIPMENT AND VOID ITS WARRANTY

CALL NOW

1.780.391.3800

TOLL-FREE 1.855.287.4477 (CTS4GPS)

CERTIFIED TRACKING SOLUTIONS

### STEP 1 Determine Installation Type and Options

Depending upon the requirements, the TT3300WR3G mini module can be installed in two ways.

- Type1 – **TT3300WR3G mini ONLY!**
- Type2 – **TT3300WR3G mini with** starter kill and/or input

### STEP 2 Complete the wire connections according to the selected installation type

Please see the following pages for detailed instructions and wiring diagrams.

<p><b>Red:</b> 12 Volts (+) Constant</p> <p><b>White:</b> Ignition (+) (MUST be a true ignition source)</p> <p><b>Black:</b> Ground</p> <p><b>Green:</b> Starter Disable Output (-)</p>	<p><b>Orange:</b> (Do Not Use)</p> <p><b>Yellow:</b> Input 1(-) Optional</p> <p><b>Blue:</b> (Do Not Use)</p> <p><b>Brown:</b> (Do Not Use)</p>
---	---

**GROUND MUST BE CONNECTED DIRECTLY TO CHASSIS WITH PAINT REMOVED**

### STEP 3 Position the TT3300WR3G mini Module in an Optimal Location

Failure to adhere to these suggestions will result in a weak cellular and/or GPS signal and will affect the performance of the device.

- Do not cover with metal or position near any source of interference (Vehicle Radio, BCM). Keep a safe distance of at least 24".

### STEP 4 Confirm LED Status

Blue: Flashing	Connected / Online	✓
Green: 1 Flash / Second	Valid GPS	✓

### STEP 5 Test

To TEST modem, call the numbers ABOVE!

### Type 1 TT3300WR3G mini only

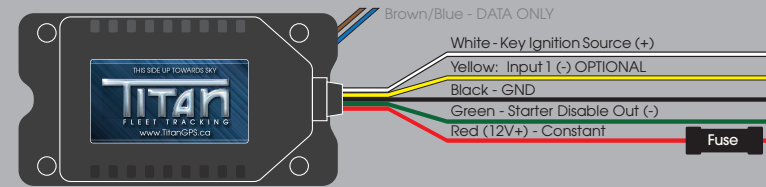

**1-2-3!**

1. Connect Red wire to Constant +12V and fuse.
2. Connect Black wire to Ground.
3. Connect White wire to True Ignition (+).



**ATTENTION:** Connecting the device to 24V or 12V to the Brown or Blue wire **WILL VOID THE WARRANTY!**

For Live Tech Support:  
Call Certified Tracking Solutions at  
**1.780.391.3800**  
Toll-Free **1.855.287.4477**  
8AM - 5PM Monday to Friday MST

Numerous installation options exist to interrupt a vehicle's start sequence. Please see one possible option below.

### Type 2 TT3300WR3G mini with Starter Kill and/or input (optional)

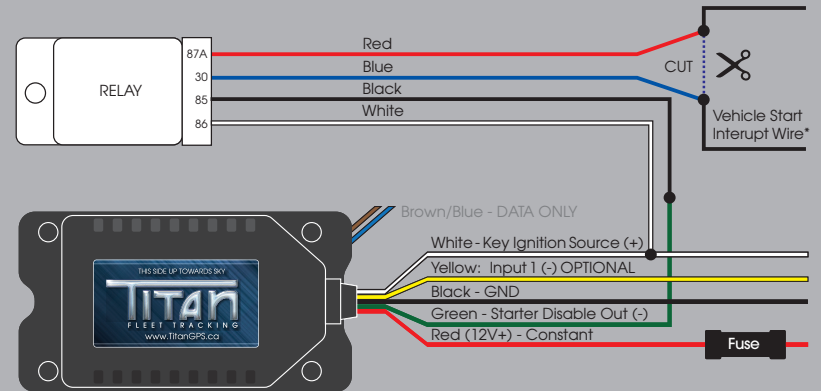

#### \*Vehicle Start Interrupt Wire

This is a wire that when cut the vehicle is not able to be started by a key. Due to data bus systems on newer vehicles this wire may not be at the ignition switch. When cutting a wire be sure to test that the vehicle cannot be started by key and when reconnected the vehicle starts without fault codes being displayed by the vehicle. **DO NOT CUT THE WIRE THAT WILL SHUT DOWN THE VEHICLE WHEN RUNNING BY THE KEY.**