

Attention:

This modem is shipped temporarily preactivated for the installer to send up to 50 test commands before having to send in the activation form.



STEP 1: Modem Install Location

To ensure a strong wireless connection, the modem must be installed in the upper portion of the dash, with little to no metal blocking the unit from the sky. Ensure the modem is installed flat with the correct side pointed skyward. The modem will have markings indicating which side is to be pointed up and down. **DO NOT** Install Modem near the vehicle's Radio or BCM "Body Control Module", keep a safe minimum distance of 18 to 24 inches.

STEP 2: Primary Modem Wire Connections

Black: Ground	Yellow: Do not use
Red: 12 Volts	Green: Starter Disable (-)
White: Ignition (MUST be a true ignition source)	Output

GROUND MUST BE CONNECT DIRECTLY TO CHASSIS WITH PAINT REMOVED

STEP 3: Confirm LED Status

Blue: No Flash	No Network	
Blue: 1 Flash / Second	No Data Connection	
Blue: 1 Flash / 4 Seconds	Connected / Online	
Green: Solid	Aquiring GPS	
Green: 3 Quick Flashes	Invalid GPS	
Green: 1 Flash / Second	Valid GPS	

STEP 4: Confirm Connectivity & GPS via Website Dashboard

- A** Log onto the Install Test Account by going to the Titan Dashboard website at TitanInnovations.ca, use the Device's Serial SID number for the login & password.
- B** Each Modem is tested at Certified Tracking Solutions in Edmonton, Alberta, Canada before being shipped to an authorized Titan dealer. When you initially log onto the Dashboard, the GPS modem may still be located at Certified Tracking Solution's head office. This means the unit has not connected to the server and reported its GPS position. If the modem has a valid cellular connection, you can force a GPS position through by cycling the vehicle's ignition on/off.
- C** The vehicle icon should have changed to your installation location, the icon should have a "Red" dot" below the vehicle, if it has a "!" dot, that means the unit has reported a position with an invalid GPS.



- D** To test GPS, make sure the vehicle has a clear view to the sky, cycle the ignition a few times and confirm that the modem is reporting a valid GPS position.
- E** If you have hooked up an input, you can confirm the connection by triggering the input and watching the "Asset Information" box update.
- F** If you have hooked up the Starter Disable output, you can test this feature by sending an "Activate Starter Kill" command. You know the command was successful if you get a checkmark. A red X means the command was not successfully executed and confirmed.

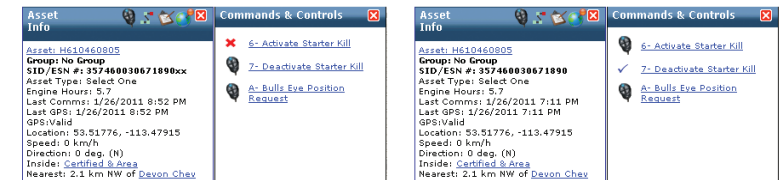

For Live Tech Support:
 Call Certified Tracking Solutions at 1-780-391-3800,
 8AM to 6PM Monday to Friday MST
www.TitanGPS.ca

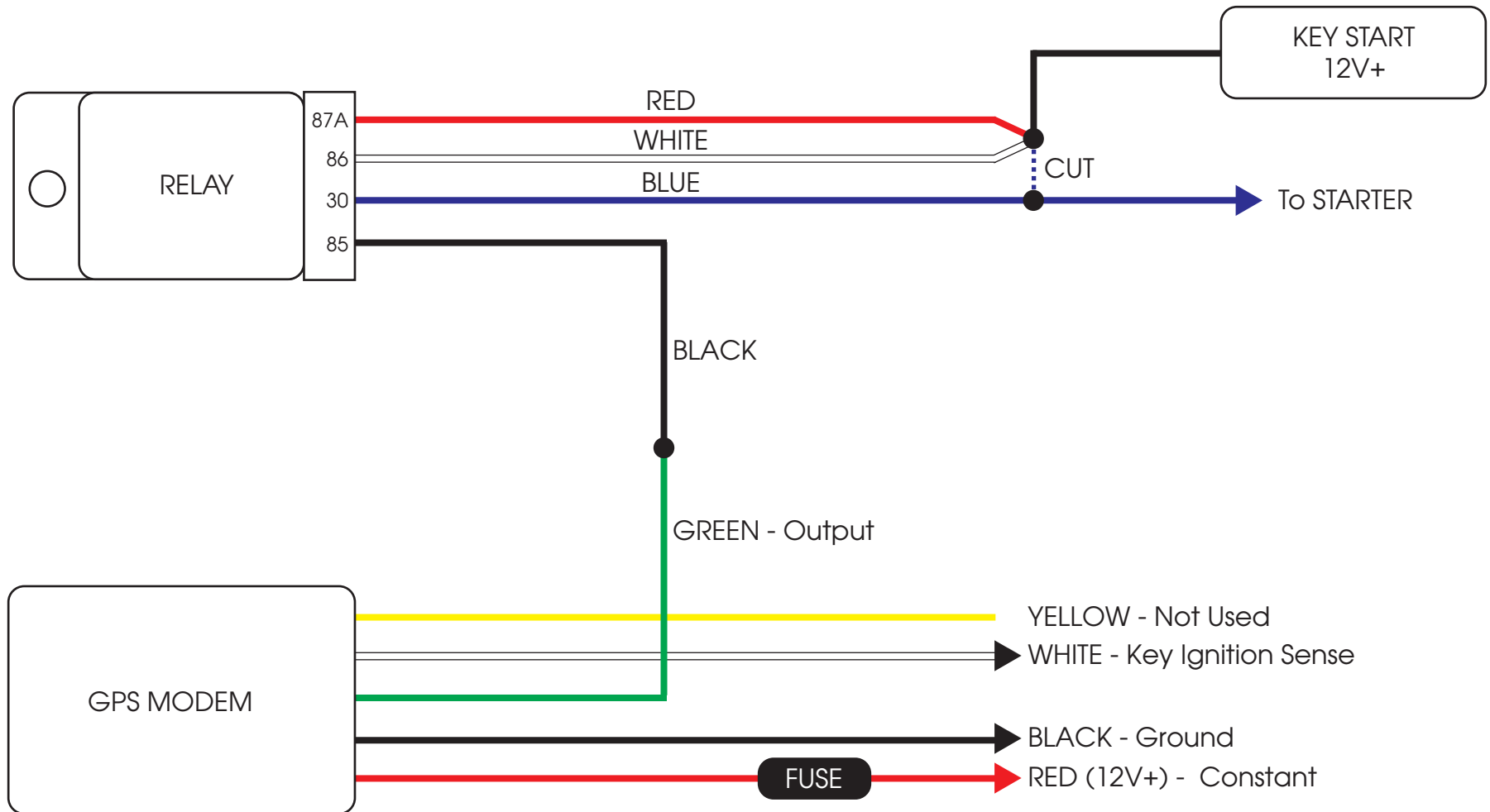

For Live Tech Support:
Call Certified Tracking Solutions at 1-780-391-3800,
8AM to 6PM Monday to Friday MST
www.TitanGPS.ca